



SNIJDER HASSELT

HYDRAULIEK & FILTERTECHNIEK

FUELMANAGER

Deisel Fuel Filter/Water Separator

User Guide



ENGINEERING YOUR SUCCESS.



FUELMANAGER[®]

Deisel Fuel Filter/Water Separator

User Guide



ENGINEERING YOUR SUCCESS.

Diesel Fuel Filter/ Water Separator System

Introduction

Fuel Manager has been making diesel fuel filters for over 30 years. Our “Square Filter” design filters, with glass or metal cases, are still seen on many off and on-road applications. But new technology and requirements from the market have resulted in a new generation of diesel fuel filters known as Fuel Manager.

What is Fuel Manager?

Fuel Manager is a diesel fuel filter/water separator system. It features a complete range of modules and features to meet any diesel filtration need. The concept is to provide everything you need, but only what you need, using a common range of interchangeable parts that can be added as needed to the basic header to provide specific features to meet specific requirements. There are two versions of Fuel Manager.

FM 100 Series is for engines with a total fuel flow of up to 80 US gals (300 liters)/hour, or about 350 HP.

FM 1000 Series is for engines with a max. fuel flow of about 180 US gals (680 liters)/hour, or about 600 HP.

Fuel Manager Modules & Options

A Fuel Manager basic assembly consists of a cast aluminum header with two inlet and two outlet female threaded ports for fuel line connections. Normally, only one inlet and one outlet are required. (The flexible design offers a choice. Unused ports should be plugged). Attached to the header is the element, which contains the media to remove water and other contaminants.

The header features a choice of female threads for fuel line connections. Standard threads for FM 100 Series are ¼” – 18 NPTF, 3/8” – 18 NPTF, ½” – 20 SAE ‘O’ ring; M12 x 1.5 ‘O’ ring; & M14 x 1.5 ‘O’ ring. Standard threads for FM 1000 Series are ½” – 14 NPTF, & 7/8” – 14 ‘O’ ring. Other threads are available.

The element features a choice of four different media, all with water repelling treatment:

150 Micron Coalescing Pre-Filter/Water Separator Element

Ideal for cold weather applications, where the special nylon media minimizes the risk of fuel wax choking. Designed to provide extra protection and remove most water and larger contaminants before they choke the final (or secondary) filter.

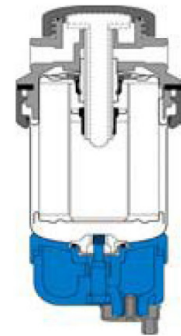

30 Micron Pre-Filter/Water Separator Element

Using chemically treated paper media to repel water, these elements offer very efficient primary filtration. Designed to be used with a final filter, a pre-filter will extend service intervals and ensure optimum protection for the injection system. Available in standard or extended duty sizes.

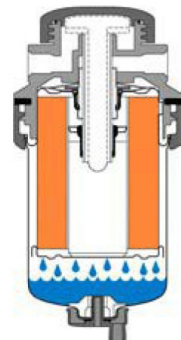

2 or 5 Micron Final Filter/Water Separator Element

Providing the ultimate in protection, a Final (or secondary) Filter can be used on its own or in combination with either a 150 micron or 30 micron pre-filter assembly for maximum service life. Final filter elements are available in a range of sizes for different service interval requirements.

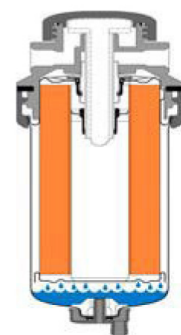

See-Thru Plastic Bowl

A See-Thru Plastic Bowl is a popular option module, allowing immediate and easy visual inspection of water and residue levels.

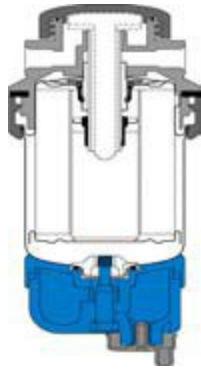

Water in Fuel Sensor

This electronic Sensor can easily be connected from the element's sump to a remote alert light. This optional electronic module signals that water has accumulated in the filter and must be drained. Ideal for applications where a see-thru bowl cannot easily be checked.

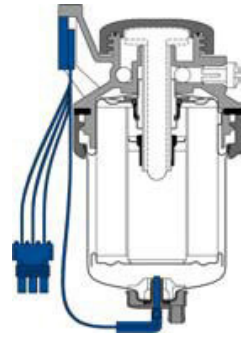

In-Unit Heater

The Fuel Manager's unique In-Unit Heater (12 or 24 volt, 100 or 150 watt) assists in cold weather start-ups. A simple and reliable sensor reacts to the fuel temperature and, when needed, activates a high-efficiency heating element. Fuel flows along the length of the heater for rapid and uniform warming.

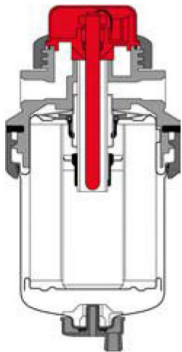

Side-Load Heater

The Side-Load Heater (12 or 24 volt, 100 watt) is designed for use in conjunction with the hand or electric pumps, providing all capabilities and benefits of the In-Unit Heater.

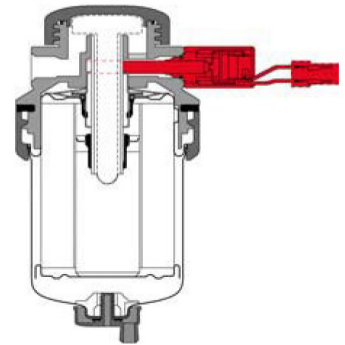

Pre-Filter Screen

This 150 micron Pre-Filter Screen fits into the modular access port and is designed to capture larger particles before they can choke the main filter media. The screen can be removed for cleaning and reused.

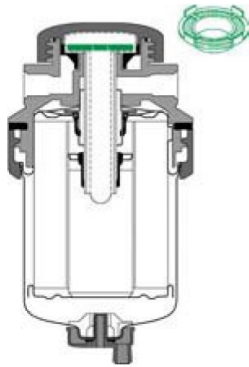

Hand Primer Pump

An optional Hand Primer quickly purges air from the fuel system after an element change, maintaining flow integrity on vacuum-side filter applications.

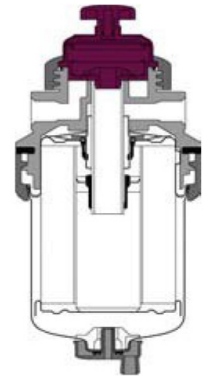

Lift Pump

The electric Lift or Boost Pump is designed to replace or supplement separate mechanical or electrical lift pumps. The Lift Pump module with integral pressure regulator mounts on top of a special assembly and provides fuel pressure to the injection pump prior to starting. The Lift Pump will help speed engine starting and reduce emissions.

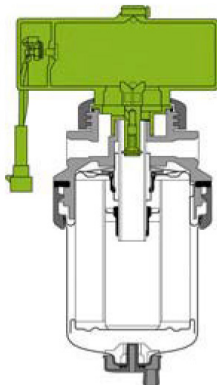

Purge Pump

The electric Purge Pump option offers a convenient method of purging air from the fuel filter. Numerous mounting options enable easy priming in applications where there is minimal engine space and maintenance access.

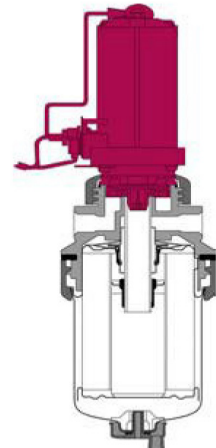

Key Features & Benefits

Of Fuel Manager FM100 & FM1000 Series

- FM 100 Series suitable for engines with fuel flow up to 80 US gals/hr. (about 350 HP).
- FM 1000 Series suitable for engines with fuel flow up to 180 US gals/hr. (about 600 HP).
- Simple to use -no tools required to change elements or install most modules.
- Easily up-graded to include extra features without disconnecting fuel lines.
- Spill-free element change.
- Extremely efficient –all filters remove water and particles. Up to 99.6% efficient @ 2-microns.
- Made by America's largest diesel fuel injection system manufacturer.
- Specified by major OEMs such as John Deere, GM, Perkins, Ford, Caterpillar, Case, New Holland, SISU, and others.

Installation

The header should be mounted to the engine or frame, on either pressure or suction side of the transfer pump (if installed). Maximum operating pressure of the filter is 60 psi.

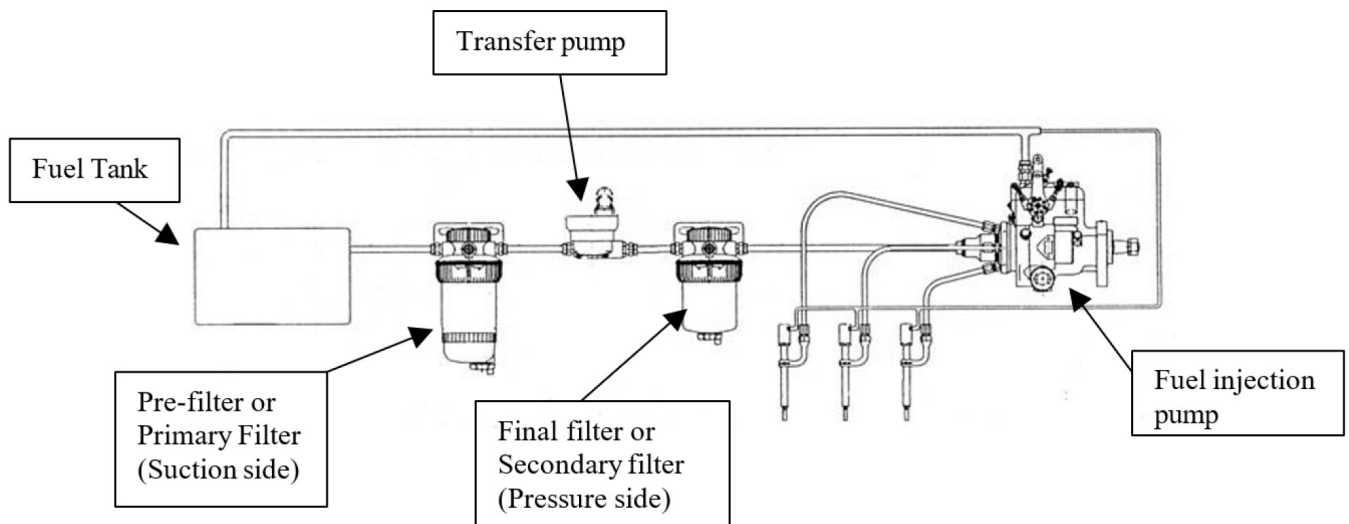

Two inlet & two outlet ports are provided, and clearly marked with arrows. Install a plug in unused ports.

Select the correct media-rating element. Use a 150 or 30 micron element for a pre-filter (must also have a 5 or smaller micron filter "downstream"); or if only a single filter installation, use a 5 or 2 micron element. Factory-assembled complete units are available.

Add any module features such as see-through bowl; water-in-fuel sensor; heater etc.

Heaters are available for 12 or 24 volts application. Each heater has an integral thermo-switch, which automatically turns on the heater when temperatures fall, and switches it off when temperatures rise again. Connect the wiring to a switched ignition source as shown in the directions included with each kit module package.

The pre-filter screen can be installed in all assemblies except the electric lift and purge pump units. It is ideal to catch large particles, and can be removed for cleaning and re-used.

The electric lift and purge pump units are sold only as complete assemblies. They have a special flow configuration so that the fuel is filtered before passing through the electric pump. The fuel line connections are "reversed" from the conventional header. The correct inlet and outlet ports are clearly marked with arrows on the headers. Only special "reverse flow" filter elements can be used with the electric pump assemblies.

When first installing or changing elements, prime the assembly by venting air from the filter. Open the air vent on the front of the header, and allow fuel to flow into the filter (gravity or low pressure pump). Close the vent plug.

Service

- Check the filters for water regularly, and drain as required.
- If a see-through bowl is installed, visual checking is easy. Water will collect at the bottom of the bowl, and appears a different color from the fuel. Drain water by opening the self-venting drain valve and allowing all water to escape. The see-through bowl is re-usable.
- If an electronic water-in-fuel sensor and warning light is fitted, drain when the light illuminates, indicating that water has accumulated. Temporarily remove the water sensor cable from the special drain valve, open the valve until all water has escaped, re-tighten the valve and replace the electric cable to the metal stud on the drain valve. Note that the special drain valves for the electronic water sensor can be re-used for replacement elements.
- Change the element canister when necessary –usually every 500 hours or 15,000 miles for a final filter element; 1000 hours for a 150 micron pre-filter.
- To change an element, first loosen the large black retaining ring. Pull the element straight down –do not twist, the element is not threaded. Dispose of the old element properly. Align the logo of the new element to the front of the header and make sure the “keys” on the element are aligned with slots in the header. (See illustrations on each element). Push the new element up to the header. Hand-tighten the retaining ring until it “clicks” and the arrows line up in the center of the header. Purge air from the new element (see above).
- A major cause of hard starting or loss of power is air in the system. Check all connections, the air vent, drain valve, and any other potential leak.
- Install an optional hand primer pump module if frequent element changes are necessary, or if purging

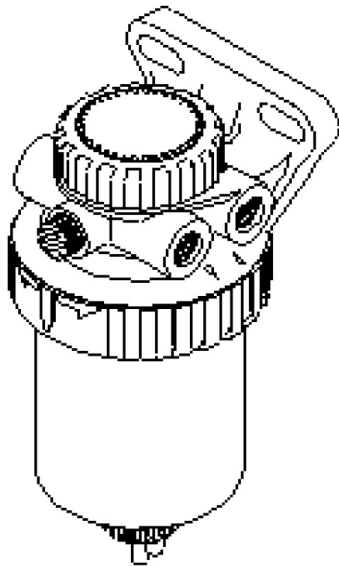

Basic Fuel Manager FM 100

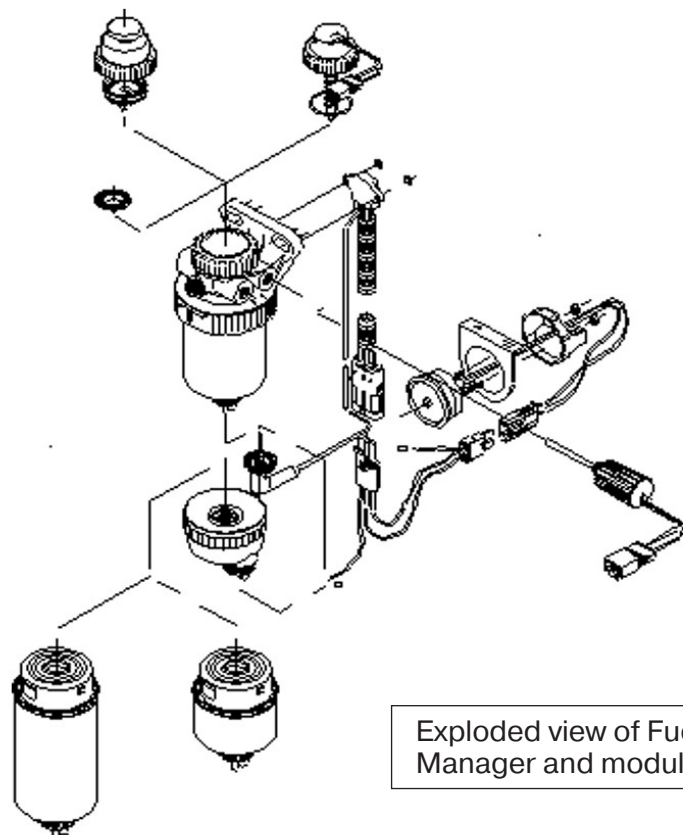

Exploded view of Fuel Manager and modules

www.parker.com/emfe



European Headquarters

La Tuiliere 6, 1163 Etoy,
Switzerland
Tel: +41 21 821 85 00

EMEA Product Information Centre

Free phone: 00 800 27 27 5374
(from AT, BE, CH, CZ, DE, DK, EE, ES, FI, FR, IE, IL, IS,
IT, LU, MT, NL, NO, PL, PT, RU, SE, SK, UK, ZA)
US Product Information Centre
Toll-free number: 1-800-27 27 537